

# ROEQ TR600/1000 Top Roller solution for Continental IL 1200



The ROEQ TR600 & TR1000 are heavy duty top rollers for your Continental mobile robots. They can pick up and deliver heavy goods between conveyor stations on your production line and are ideal for transporting US and euro pallets

The full solution includes the ROEQ GuardCom system which provides additional safety and efficiency when transferring between the top roller and the receiving station, using robust sensor technology. Developed with ROEQ Safety features and ROEQ Assist software for faster and consistent set-up.



Two package function

## Features

- Can handle payloads of up to 600 kg/1000 kg.
- The flat top allows transfer of wide loads which extend over the sides. Side Bars can be purchased, if required.
- Built-in barriers on rollers protect fingers
- Long Cargo Kit available for safe transfer of long loads
- The TR1000 can handle and deliver two packages individually
- Built-in position sensor confirms correct position of robot before transfer of goods
- Cargo sensors in the front and back ensure safe transfer and transport of cargo
- Compatible with ROEQ GuardCom System for additional safety and optimal performance to/from conveyor stations. Wireless communication without reliance on Wi-Fi

## Specifications

**Robot compatibility:**  
Continental IL 1200

**ROEQ product compatibility:**  
GuardCom System

**Payload:**  
TR600: 600 kg  
TR1000: 1000 kg

**Size (l x w):**  
1435 x 1097

**Cargo area:**  
1300 x 1066 mm  
Note: Loads can extend over the sides.  
Add the Long Cargo Kit for longer loads.

**Height from floor to rollers:**  
400 mm

**Sensors:**  
Position sensors and cargo sensor

Use the ROEQ GuardCom to improve cycle time and decrease downtime





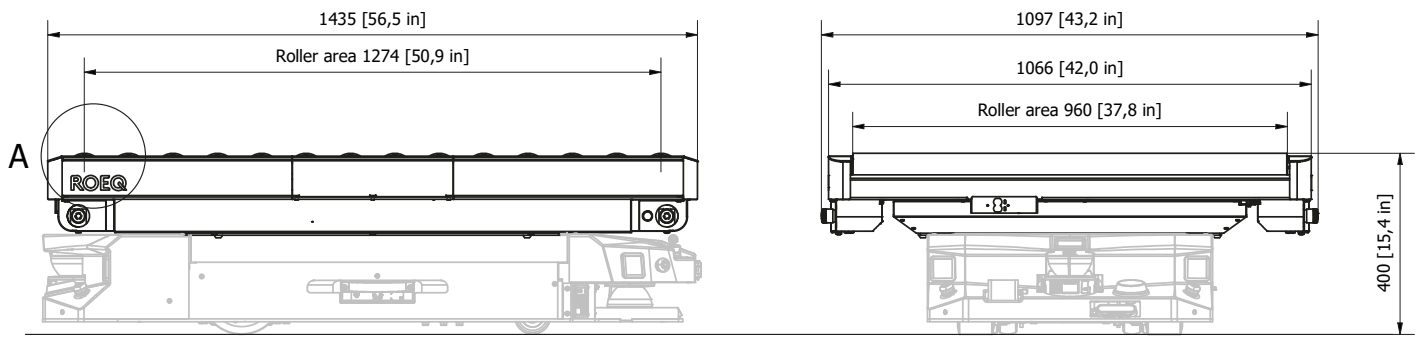



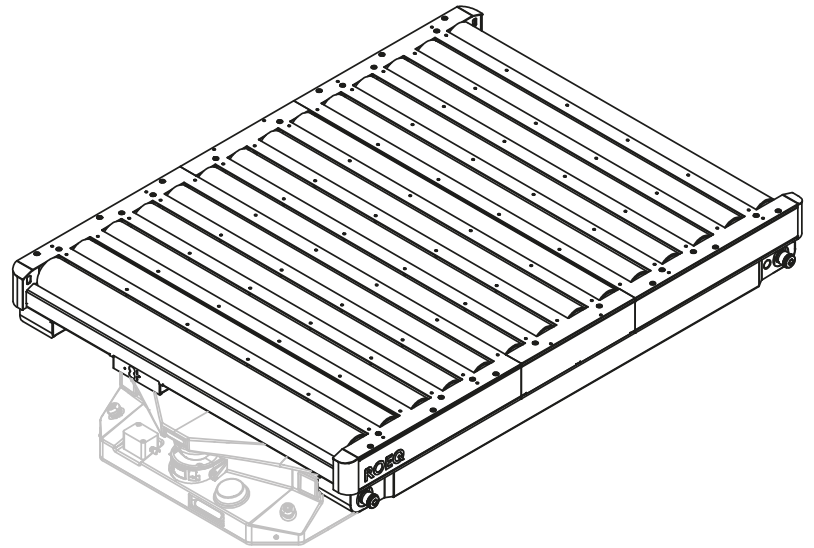
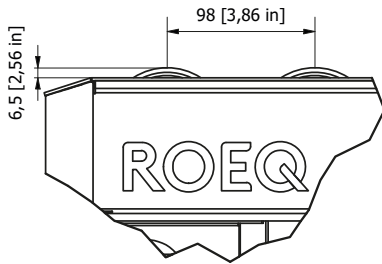

**ROEQ**  
ROBOTIC EQUIPMENT



Detail A



Product no.	Product name	Description	
700s1000	TR600	Top roller with fixed height. Payload 600 kg	
700s2000	TR1000	Top roller with fixed height. And two package function. Payload 1000 kg	
273a1000	GuardCom	GuardCom unit to mount on static conveyor, for efficient and safe transfer of goods	 
273a2000	GuardCom Connect	Communication unit to mount on top rollers. Wireless communication with GuardCom, not using Wi-Fi	
700s4100	Side Bars	For additional safety, when loads do not exceed the width of the roller area suitable for US and Euro pallets	
700s4200	Long Cargo Kit	For safe transfer of long cargo	
700s4300	Height Kit	Kit for increasing the height of TR600/1000	

[Visit roeq.dk](http://roeq.dk)